

TO: James L. App, City Manager
FROM: Doug Monn, Director of Public Works
SUBJECT: Revise Standards for ADA Compliance
DATE: May 1, 2007

Needs: For the City Council to consider the adoption of new standards for sidewalk ramps, driveways and alley approaches for ADA compliance.

Facts:

1. Standard designs for compliance with the American Disabilities Act (ADA) have changed for public sidewalk ramps and paths of travel over public sidewalks.
2. The City Engineer has prepared updated standards for sidewalk ramps, driveways and alley approaches consistent with the most recent ADA design requirements. These standards have been reviewed by the City's ADA compliance consultant.

Analysis and

Conclusion: It is essential that new public works construction comply with current ADA requirements. The attached standards have been reviewed for compliance and are ready for distribution to the development community.

Policy

Reference: City Standard Details and Specifications.

Fiscal

Impact: None.

Options:

- a. Adopt Resolution No. 07-xx revising Standard Drawings B-6, B-9.1, B-9.2, B-11 and B-12 as attached.
- b. Amend, modify or reject the option above.

Prepared by: John Falkenstien, City Engineer

Attachments: (7)

1. Resolution
2. City Standard B-6
3. City Standard B-9.1
4. City Standard B-9.2
5. City Standard B-10
6. City Standard B-11
7. City Standard B-12

RESOLUTION NO. 07-

A RESOLUTION OF THE CITY COUNCIL OF THE
CITY OF PASO ROBLES ADOPTING CITY STANDARD
DETAILS FOR SIDEWALK RAMPS, DRIVEWAYS AND ALLEY APPROACHES

WHEREAS, designs for compliance with the American Disabilities Act have changed for public sidewalks and paths of travel since the last adoption of City Standard Details and Specifications in 1995; and

WHEREAS, the City Engineer has prepared updated standards for sidewalk ramps, driveways and alley approaches consistent with the most recent ADA design requirements; and

WHEREAS, the adoption of revised standards for sidewalk ramps, driveways and alley approaches is exempt from environmental review in accordance with Section 15061(b)(3) of the Guidelines to Implement the California Environmental Quality Act. These standards will not have a significant effect on the environment.

NOW, THEREFORE, BE IT RESOLVED, DETERMINED, AND ORDERED as follows:

SECTION 1. That the City Council of the City of El Paso de Robles does hereby revise Standard Drawings B-6, B-9.1, B-9.2, B-10, B-11 and B-12, as attached.

PASSED AND ADOPTED by the City Council of the City of Paso Robles this 1st day of May, 2007, by the following vote:

AYES:

NOES:

ABSTAIN:

ABSENT:

Frank R. Mecham, Mayor

ATTEST:

Deborah D. Robinson, Deputy City Clerk

REVISIONS

DESCRIPTIONS	BY	DATE	APPROVED

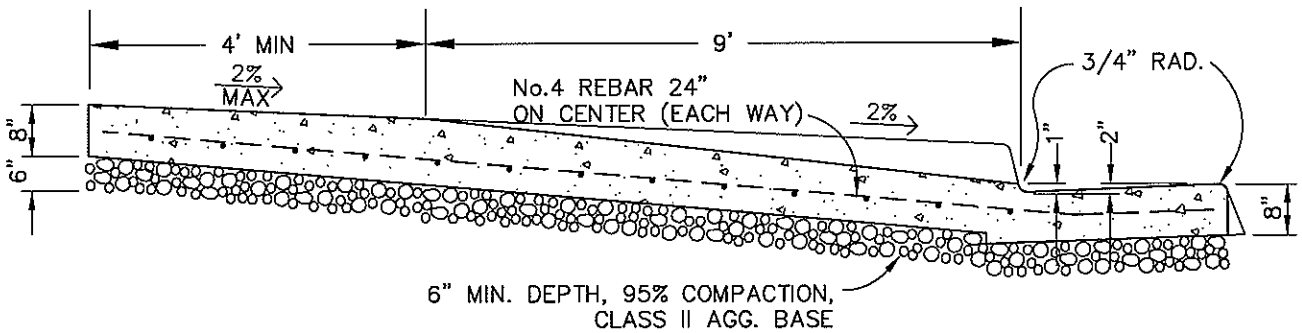
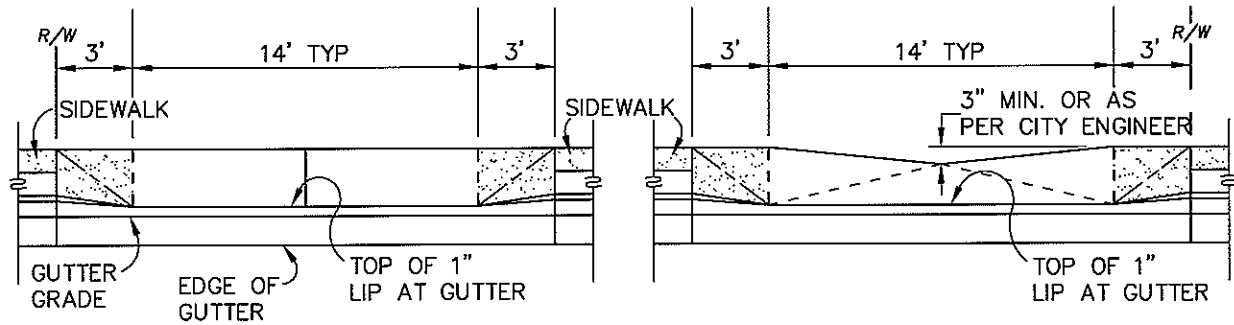
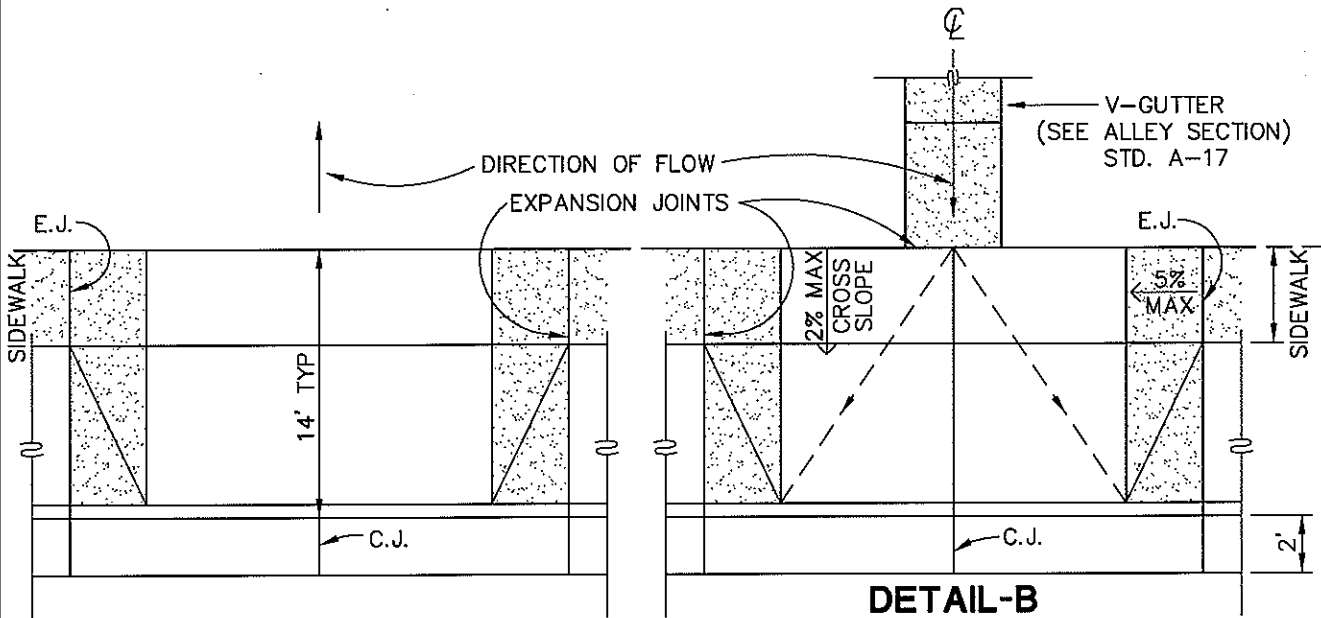

TYPICAL SECTION

NOTE: CONCRETE SHALL BE 6 SACK CRUSHED AGGREGATE 3/4" AT 3000 PSI

DRAWN BY: K.S.B.	CITY OF PASO ROBLES ENGINEERING DIVISION	DRAWING NO.
DESIGNED BY:		
DATE: 01/31/07	ALLEY APPROACH DETAIL	B-6
FILE NAME: PR-B-6.DWG		

REVISIONS			
DESCRIPTIONS	BY	DATE	APPROVED

NOTES

1. Slopes, ramp and passageway thicknesses, "T", shall be 3 1/2" minimum.
2. Minimum width of passageway through raised islands shall be 6'-0", except for locations where right of way conditions create an unreasonable hardship. The clear width of the passageway may be reduced to 3'-0".
3. For details of grooving used with Case CH curb ramp, see Revised Standard Plan RSP 488A.
4. For details of detectable warning surfaces, see Revised Standard Plan RSP 488A.
5. Where on island passageway length is less than 8'-0", the detectable warning surface shall extend the full width of the island. Where on island passageway length is greater than 8'-0", but less than 10'-0", it shall be 6'-0" wide and extend the full width of the island. Where on island passageway length is greater than 10'-0", it shall be 6'-0" wide and extend the full width and 3'-0" depth of the passageway length.
6. For Case CH curb ramps, the edge of the detectable warning surface shall be flush with the gutter line.
7. Transitions from ramps to walks, gutters or streets shall be flush and free of abrupt changes.
8. Maximum slope of adjoining gutters, the road surface immediately adjacent to the curb ramp and continuous drainage to the top of bottom of the curb ramp.
9. ADAAG shall be followed with and other applicable codes, unless the manufacturer of the ramp is relocated or adjusted to grade by the owner prior to, or in conjunction with, curb ramp construction.
10. For additional curb ramp details, see Revised Standard Plan RSP 488B.

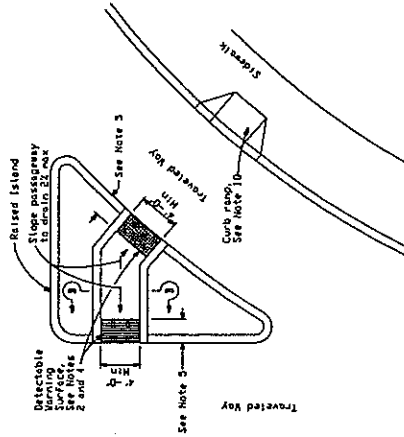

TYPE B PASSAGEWAY

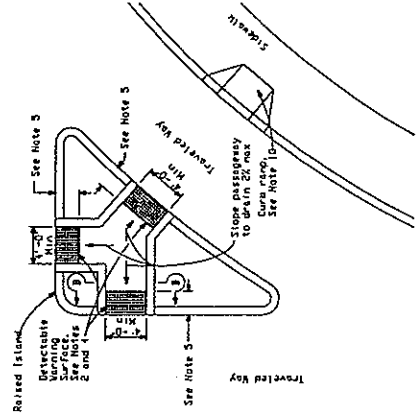

TYPE C PASSAGEWAY

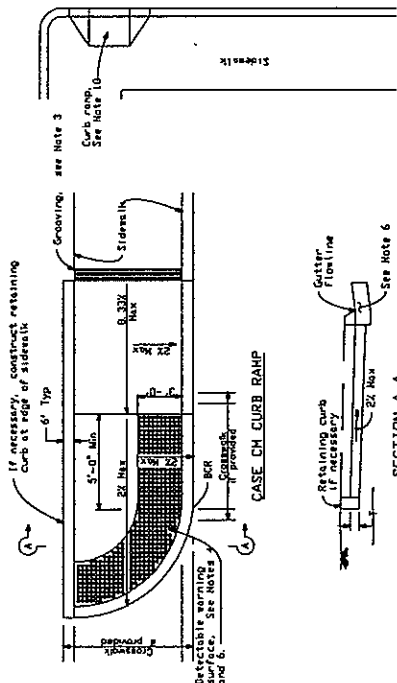

SECTION A-A

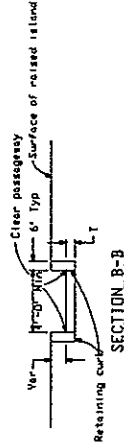

SECTION B-B

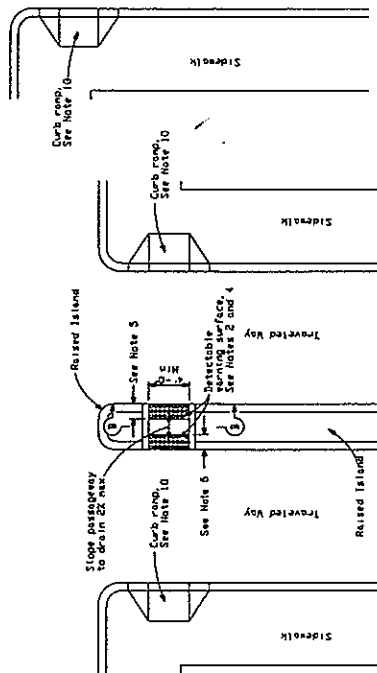

TYPE A PASSAGEWAY

DRAWN BY:
K.S.R.
DESIGNED BY:
DATE:
00/00/00
FILE NAME:
PR-B-9.2.DWG

CITY OF PASO ROBLES
ENGINEERING DIVISION
CURB RAMP AND
ISLAND PASSAGEWAY DETAILS

DRAWING NO.
B-9.2

STATE OF CALIFORNIA
DEPARTMENT OF TRANSPORTATION
STANDARD PLAN B-9.2 (REVISED) FOR THE STANDARD PLAN BOOK DATED JULY 2002
REVISED DUAL UNITS STANDARD PLAN RSP 488B

REVISIONS			
DESCRIPTIONS	BY	DATE	APPROVED

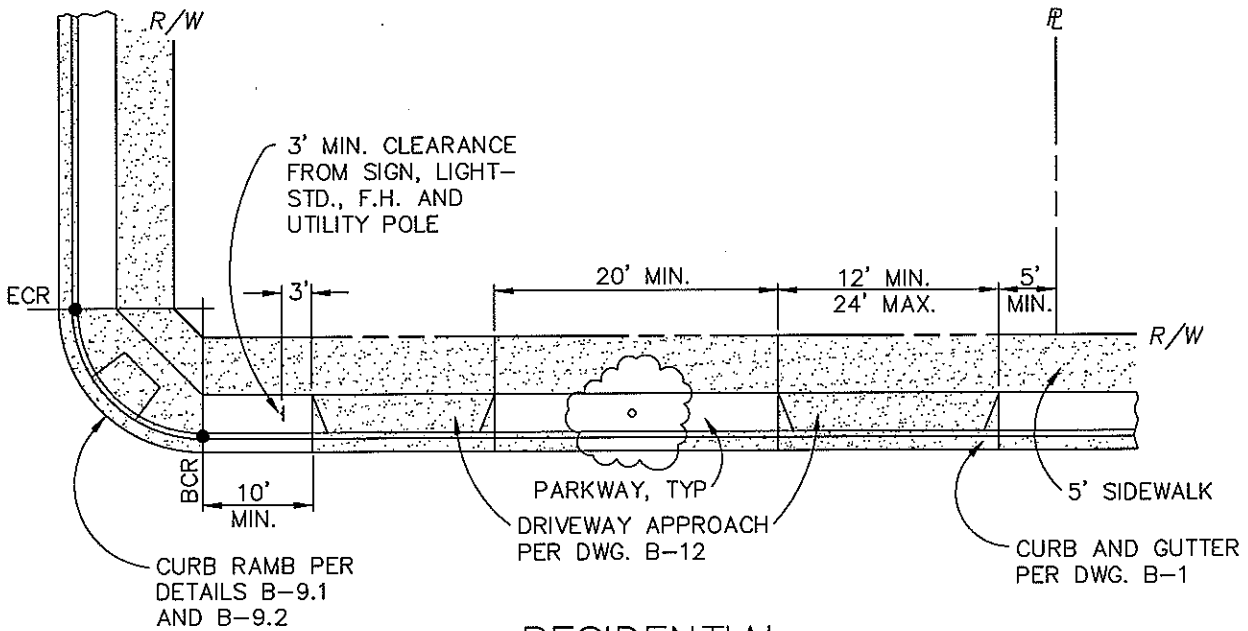

RESIDENTIAL

NOTE:

1. NOT MORE THAN TWO DRIVEWAYS PER FRONTAGE.
2. 12' MIN. WIDTH FOR RESIDENTIAL DRIVEWAYS OVER 50' LONG.

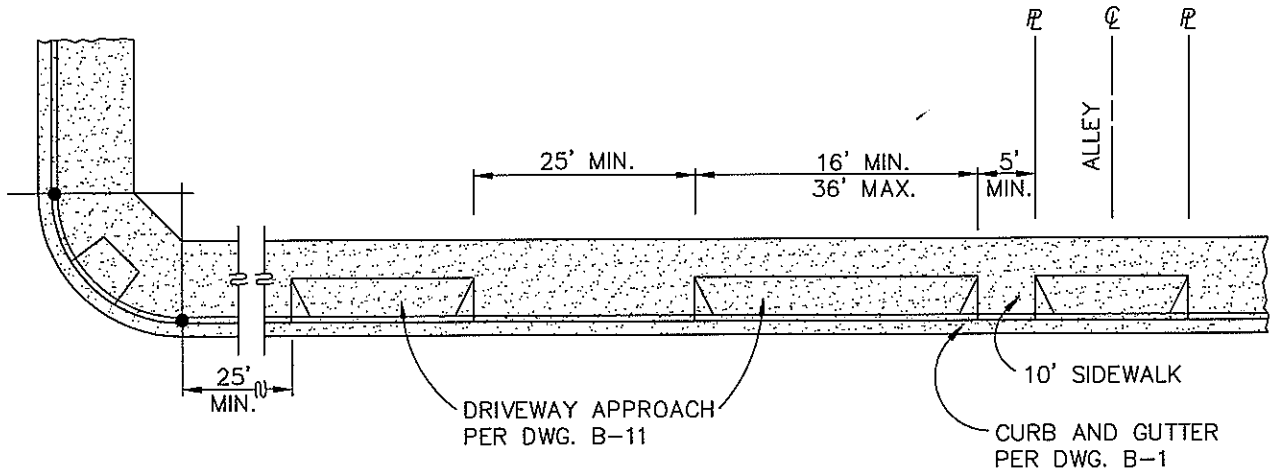

COMMERCIAL/INDUSTRIAL

NOTE:

1. TWO-WAY DRIVES SHALL BE A MINIMUM OF 24 FEET IN WIDTH, ONE-WAY DRIVES A MINIMUM OF 16 FEET.

DRAWN BY:
K.S.B.

DESIGNED BY:

DATE:
01/31/07

FILE NAME:
PR-B-10.DWG

CITY OF PASO ROBLES
ENGINEERING DIVISION

DRAWING NO.

DRIVEWAY LOCATIONS

B-10

REVISIONS

DESCRIPTIONS	BY	DATE	APPROVED

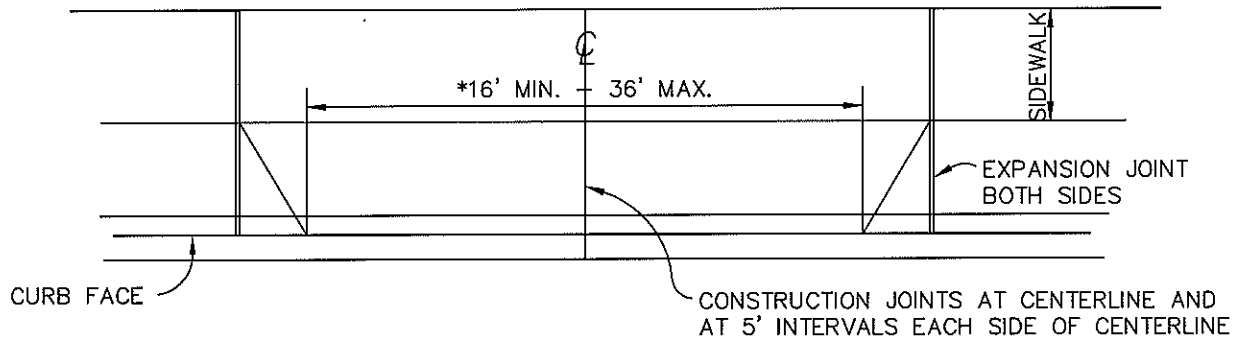

*MIN. DRIVEWAY WIDTH OF 30' FOR TWO-WAY TRAFFIC. REDUCED DRIVEWAY WIDTHS MAY BE USED WITH APPROVAL BY THE CITY ENGINEER.

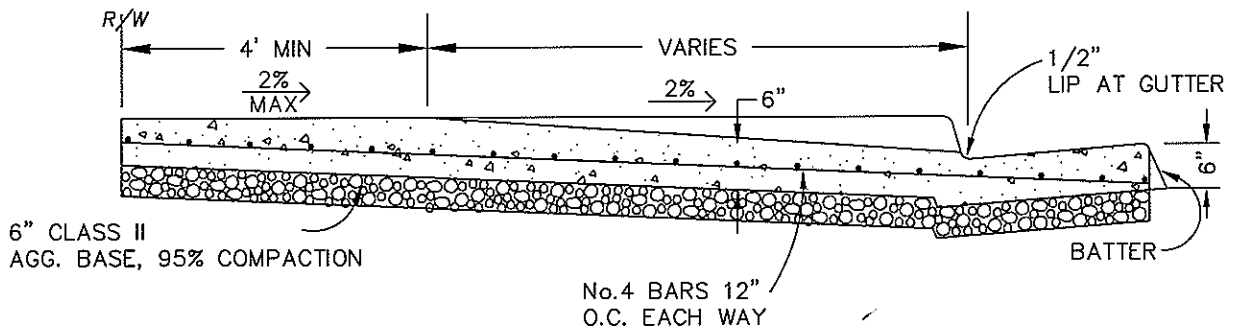
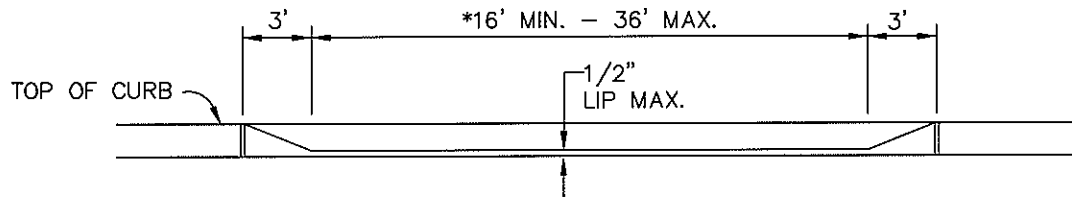

NOTES:

1. CONCRETE - 6" THICK IN DRIVEWAY AND SIDEWALK IN DRIVEWAY AREA. MONOLITHIC WITH CURB AND GUTTER. CONCRETE SHALL BE 6 SACK CRUSHED AGGREGATE 3/4", 3000 PSI
FINISH - SLIP RESISTANT PER CBC SEC. 1133.B.7.1
2. DRIVEWAY DEPRESSIONS IN NEW CURB AND GUTTER WILL NOT BE PERMITTED WITHOUT A RAMP.
3. CONSTRUCTION JOINTS SHALL BE 1/2" MIN. DEEP AND CORRESPOND WITH LINES IN ADJACENT WALK.
4. ALLOWABLE FRONTAGE
MAX. 70% OF FRONTAGE IF LESS THAN 100' FRONTAGE.
MAX. 60% OF FRONTAGE IN EXCESS OF 100'.
MIN. 20' OF FULL-HEIGHT CURB BETWEEN DRIVEWAYS ON EACH PROPERTY.
MAX. 35' WIDTH COMBINED DRIVEWAYS ON ADJACENT PROPERTIES, WITH THE CONSENT OF BOTH PROPERTY OWNERS.
5. INDUSTRIAL DRIVEWAYS SHALL BE INSTALLED AS COMMERCIAL.

DRAWN BY: K.S.B.	CITY OF PASO ROBLES ENGINEERING DIVISION	DRAWING NO.
DESIGNED BY:		
DATE: 01/31/07	COMMERCIAL DRIVEWAY	B-11
FILE NAME: PR-B-11.DWG		

REVISIONS			
DESCRIPTIONS	BY	DATE	APPROVED

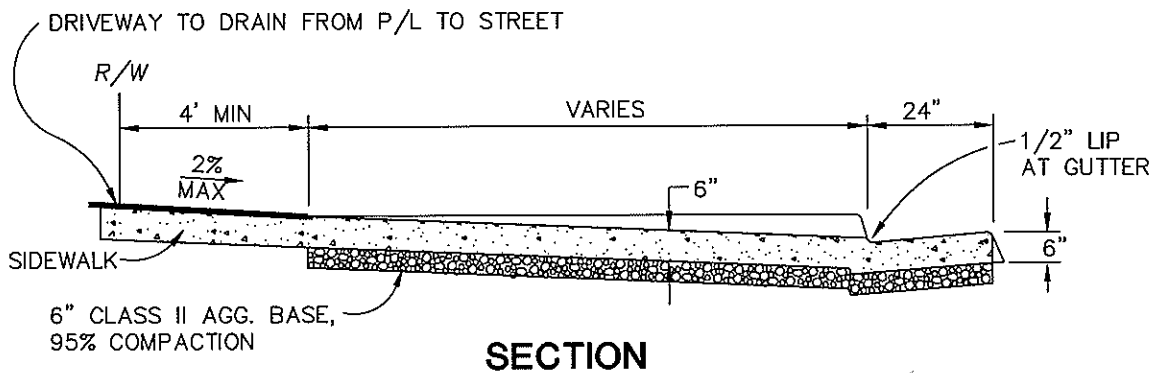
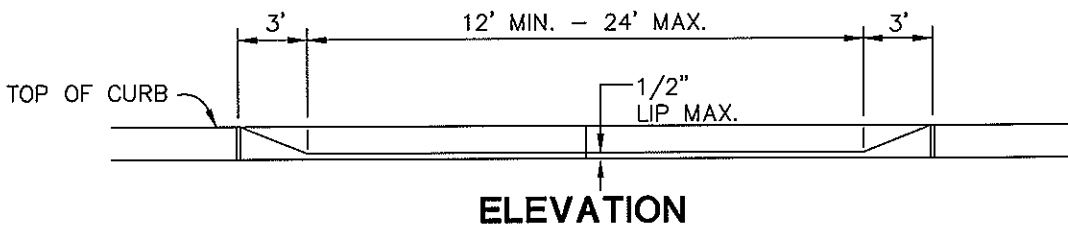
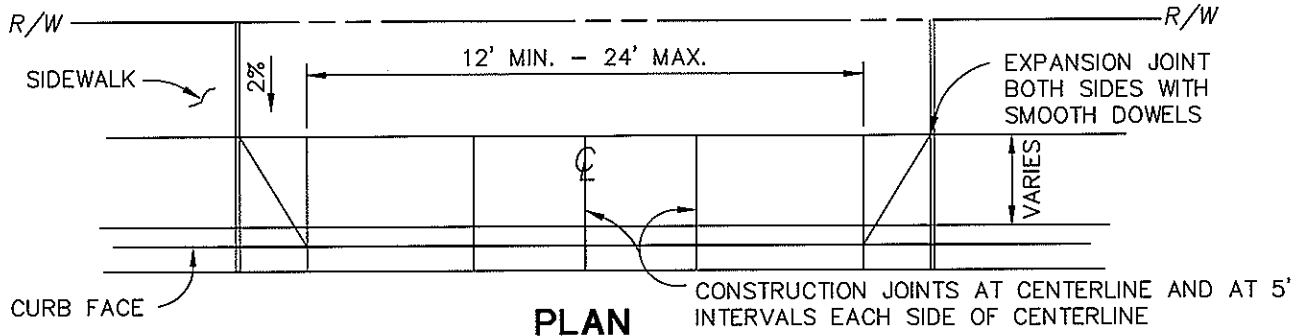

NOTES:

1. CONCRETE - 6" THICK IN DRIVEWAY AND SIDEWALK AREA. MONOLITHIC WITH CURB AND GUTTER. CONCRETE SHALL BE 5 SACK CRUSHED AGGREGATE, 3/4", 2500 PSI
FINISH - SLIP RESISTANT PER CBC SEC. 1133.B.7.1
2. DRIVEWAY DEPRESSIONS IN NEW CURB AND GUTTER WILL NOT BE PERMITTED WITHOUT A RAMP.
3. CONSTRUCTION JOINTS SHALL BE 1/2" MIN. DEEP AND CORRESPOND WITH LINE IN ADJACENT WALK.
4. ALLOWABLE FRONTAGE - MAX. 50% OF STREET FRONTAGE, MAX. TWO DRIVEWAYS.
5. MULTI-UNIT DEVELOPMENTS WITH INTERNAL TRUCK TRAFFIC SHALL USE #4 BAR REINFORCING THROUGHOUT THE DRIVEWAY SECTION.

DRAWN BY: K.S.B.	CITY OF PASO ROBLES ENGINEERING DIVISION	DRAWING NO.
DESIGNED BY:		
DATE: 01/31/07	RESIDENTIAL DRIVEWAY	B-12
FILE NAME: PR-B-12.DWG		